

apply silicone sealant to back side of connector after installing terminals

The bulkhead connector from this front light kit must snap into the mating engine connector (bag J), as shown. After snapping together, bolt the assembly into the dash harness firewall connector using the attached bolt.

## OPTIONAL Add-On Equipment:

Look!



American Autowire also sells factory OEM style harness wrap. This is the same stuff used on original Chrysler harnesses! If you want that OEM look with your Classic Update wiring system, then give us a call and order p/n R0067108 !



500093  
Weatherproof  
Universal  
Relay Kit



500479  
Universal  
Relay Kit

 **American  
Autowire**  
www.americanautowire.com 856-933-0801

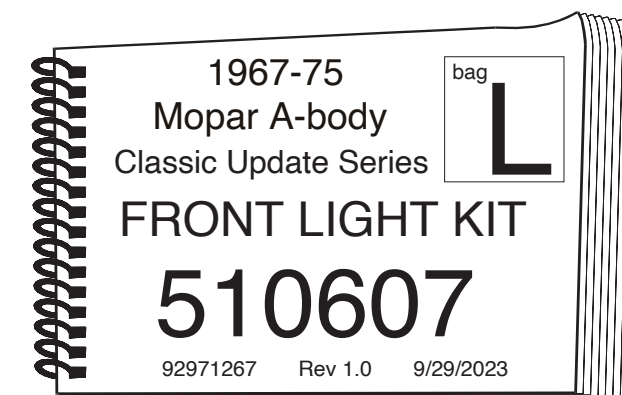

Optional Wires to be plugged into the Bulkhead Connector:

<u>Wire Color / Printing</u>	<u>Description</u>
<u>1. Washer Pump</u> Tan / no printing	If you have an Electric Washer Pump obtain the tan wire (circuit 94) and plug it into the Bulkhead Connector as shown on pages 4 and 5. This wire is the feed wire for the Electric Washer Pump and will be routed with the Front Light wires and should be connected to the Electric Washer Pump.

<u>2. Electric Fan</u> Orange / Electric Fan	If you have an Electric Fan obtain the orange "ELECTRIC FAN" wire (circuit 300) and plug it into the Bulkhead connector as shown on pages 4 and 5. This wire is a 12V Accessory feed wire which comes directly from the Fuse Block and is intended to be used as the relay trigger wire for the Electric Fan. Route this wire to a relay kit. <b>Note: An Optional Relay Kit (Universal Relay Kit 500479 or Universal Waterproof Relay Kit 500093) can be purchased from AAW (see Page 1).</b>
---	---

Preparing Light Sockets

Park/Turn Light Socket and Pigtail Assemblies  
For all vehicles you will use your original Park/Turn Light Socket and Pigtail Assembly but will have to replace the original pigtail connector (see pages 4 and 5) with 3-way connector H and terminals J from the Loose Parts Kit **92971268**. Cut the original connector from the pigtail and crimp on a terminal J to each wire. Plug these wires into connector H. Note that the wire function/colors are as follows:  
Turn Signal - black/green (Mopar) to blue (AAW),  
Park Lights - black/yellow (Mopar) to brown (AAW),  
Ground – black (Mopar) to black (AAW)  
Note: if you have a separate ground tab on your original Park/Turn Light Socket and Pigtail Assembly obtain the Park Light Ground Jumper U and connect one end to your ground tab on your Park/Turn Light Socket and Pigtail Assembly and route the wire to connector H, cut to length, crimp on terminal J and plug into connector H. Obtain the other end of the Park Light Ground Jumper U and repeat the process with the other Park/Turn Light Socket and Pigtail Assembly.

Side Marker Light Socket and Pigtail Assemblies

For the **1968-71** vehicles you will replace your original Side Marker Assembly with the Side Marker Pigtail R.  
For the **1972-75** vehicles you will replace your original Side Marker Assembly with the Side Marker Pigtail S.

Standard Wires already plugged into the Bulkhead Connector:

<u>Wire Color/Printing</u>	<u>Description</u>
<u>1. Wiper Motor</u> Brown / no printing	Armature feed from the Wiper Switch to the Wiper Motor
Dark Blue / no printing	Motor Field #1 feed from the Wiper Switch to the Wiper Motor.
Red / no printing	Motor Field #2 feed from the Wiper Switch to the Wiper Motor.
Dark Green / no printing	Park feed from the Wiper Switch to the Wiper Motor.

These four wires come from the Bulkhead connector and are already plugged into a 4-way connector in your Front Light Harness that will connect to the Wiper Motor pigtail. Obtain the 4-way mating connector N and four terminals D in the Loose Parts Kit **92971268**. Cut the four Wiper Motor wires (brown, red, dark green and dark blue) from the original Wiper Motor pigtail 8-way connector. Note that these wires are all next to each other on one side of the 8-way connector and that there may be extra wires in the 8-way connector, but these will not be used. Crimp on terminal D to each of the four wires and plug into connector N. Maintain color continuity (brown to brown, blue to blue, red to red and green to green) when you plug the wires in connector N. The 2-speed Wiper Motors have a Jumper Harness attached (available from the Aftermarket) and the 3-speed and Variable Speed Wiper Motors have a pigtail.

2. Brake Warning Switch

Tan / BRAKE LIGHT/SWITCH	This tan wire comes from the Bulkhead Connector and has a molded 1-way right angle connector at the other end. Route this wire to your Brake Warning Switch, which is attached to your Brake Pressure Differential Switch, and plug the molded connector to the switch.
--------------------------	---

3. Park Light/Side Marker Light Wire Connections

Brown / PARK LIGHTS	For the left hand (LH) Park Light/Side Marker Light connections obtain the shorter brown "PARK LIGHTS" wire (circuit 9A) from the Front Light Harness and route the loose end of this wire to the left Park/Turn Signal Light Pigtail and cut to length. Crimp on terminal D, and plug into 3-way connector F. If you have a Side Marker Light double this brown wire with the cutoff portion, crimp on terminal E and plug into connector F. Route the loose end to the LH Side Marker Light and cut to length, crimp on terminal Q and plug into the 2-way connector P as shown on pages 4 and 5.
---------------------	---

For the right hand (RH) Park Light/Side Marker Light connections repeat the process with the longer brown "PARK LIGHTS" wire (circuit 9B).

4. LH Turn Light Wire Connections

Light Blue / LEFT FRONT TURN	Obtain the light blue "LEFT FRONT TURN" wire (circuit 14) and route the loose end of the wire to the LH Park/Turn Signal Light pigtail and cut to length. Crimp on terminal D and plug into the 3-way connector F. If you have a Fender Mounted Turn Indicator, double this light blue wire with the cutoff portion, crimp on terminal E and insert into connector F. Route the loose end to the LH Fender Mounted Turn Indicator and cut to length, slide on sleeve L, and crimp on terminal K as shown on pages 4 and 5.
------------------------------	--

5. RH Turn Light Wire Connections

Dark Blue / RIGHT FRONT TURN	Obtain the dark blue "RIGHT FRONT TURN" wire (circuit 15) and route the loose end of the wire to the RH Park/Turn Signal Light pigtail and cut to length. Crimp on terminal D and plug into the 3-way connector F. If you have a Fender Mounted Turn Indicator, double this light blue wire with the cutoff portion, crimp on terminal E and insert into connector F. Route the loose end to the RH Fender Mounted Turn Indicator and cut to length, slide on sleeve L, and crimp on terminal K as shown on pages 4 and 5.
------------------------------	--

Front Headlamp Connections

6. Low Beam Wire Connections

Tan / HEADLIGHT-LOW BEAM	Obtain the tan "HEADLIGHT-LOW BEAM" wire (circuit 12) and route the loose end of the wire to the LH Headlamp, cut to length, double with the wire that was just cut off, crimp on the large terminal "B", and insert into Headlight Pigtail A from Loose Parts Kit <b>92971268</b> . Route the loose tan wire to the RH Headlamp, cut to length, crimp on the large terminal C and insert into the other Headlight Pigtail A.
--------------------------	---

7. High Beam Wire Connections

Light Green / HEADLIGHT-HI BEAM	Obtain the light green "HEADLIGHT-HI BEAM" wire (circuit 11) and route the loose end of the wire to the LH Headlamp, cut to length, double with the wire that was just cut off, crimp on the large terminal "B", and insert into Headlight Pigtail A from Loose Parts Kit <b>92971268</b> . Route the loose light green wire to the RH Headlamp, cut to length, crimp on the large terminal C and insert into the other Headlight Pigtail A.
---------------------------------	--

8. Ground Wire Connections

Black / GROUND	Each Headlight Pigtail A, has a black "GROUND" wire with a ground ring terminal and an un-terminated ground wire (circuits 150A and 150B) in each 3-way Head Light connector (see pages 4 and 5). Locate a good ground location for each ring terminal and attach to a good ground. Obtain the un-terminated black wire and route the loose end of this wire to the Park/Turn Signal Light Pigtail and cut to length, double with the cutoff portion, crimp on terminal E, and plug into 3-way connector F, double this black wire with the cutoff portion, crimp on terminal E and plug into connector F. Route the loose end to the Side Marker Light and cut to length, crimp on terminal Q and plug into the 2-way connector P as shown on pages 4 and 5.
----------------	---

Horn Wire Connections

9. Horn Wire Connections

Dark Green / HORN	Obtain the dark green "HORN" wire (circuit 29) and route the loose end to the Horn, cut to length, crimp on terminal D and insert into the 1-way connector M (see pages 4 and 5). If you have a second Horn, double this dark green wire with the cutoff portion, crimp on terminal E and plug into connector M. Route the loose end to the second Horn and cut to length, crimp on terminal D and plug into connector M.
-------------------	---

# Classic Update Series

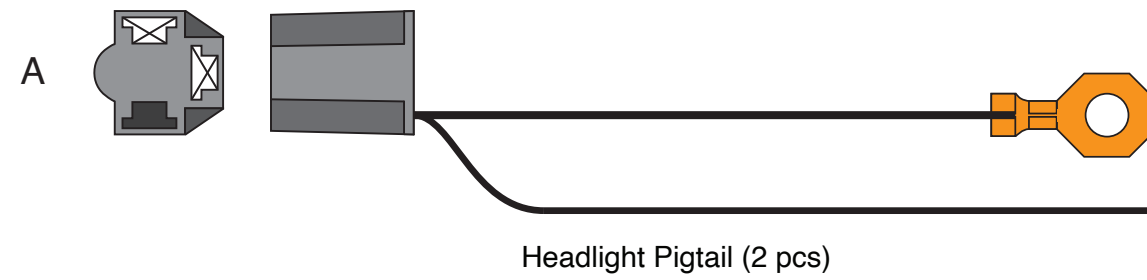

B  (59 Series double female terminal, 4 pcs)

C  (59 Series single female terminal, 4 pcs)

D  (56 Series single female terminal, 12 pcs)

E  (56 Series double female terminal, 10 pcs)

F  (56 Series 3-way female connector, 2 pcs)

H  (56 Series 3-way male connector, 2 pcs)

J  (56 Series single male terminal, 9 pcs)

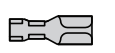
K  Single female bullet terminal, 4 pcs)

L  Large rubber sleeve, 4 pcs)

M  (56 Series 1-way female connector, 2 pcs)

N  (56 Series 4-way female connector, 1 pc)

P  (Pack Con 2-way female connector, 2 pcs)

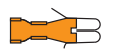
Q  (Pack Con single female terminal, 6 pcs)

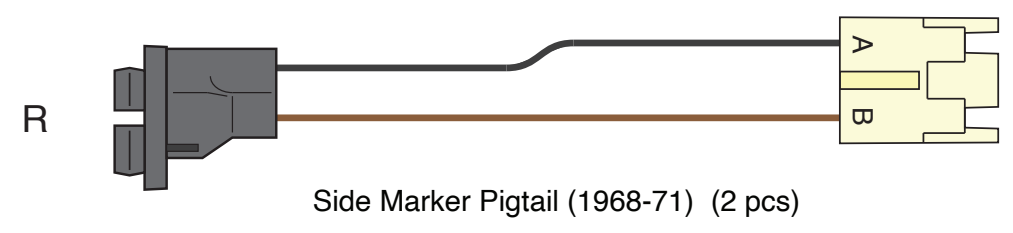

# Classic Update Series

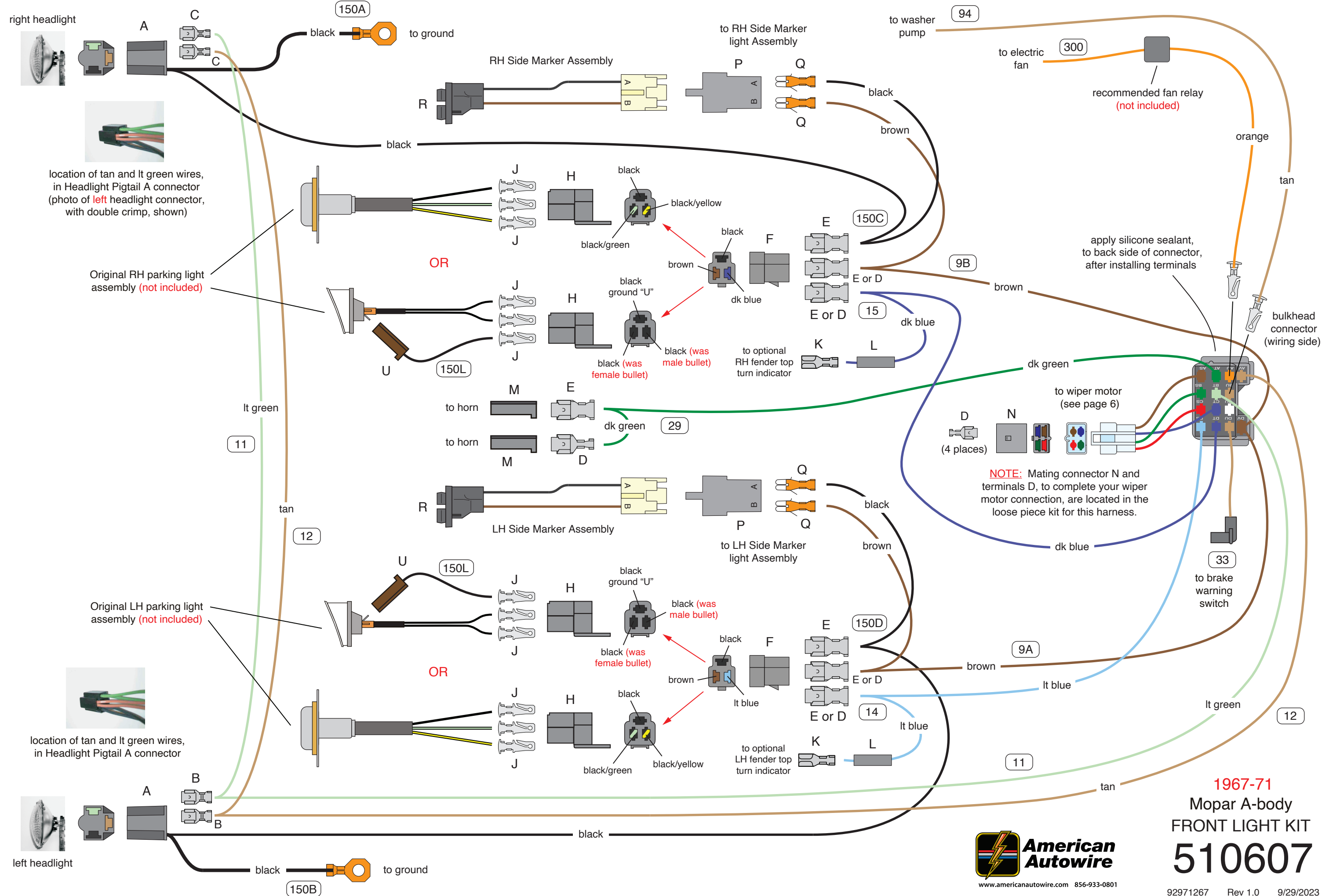

# Classic Update Series

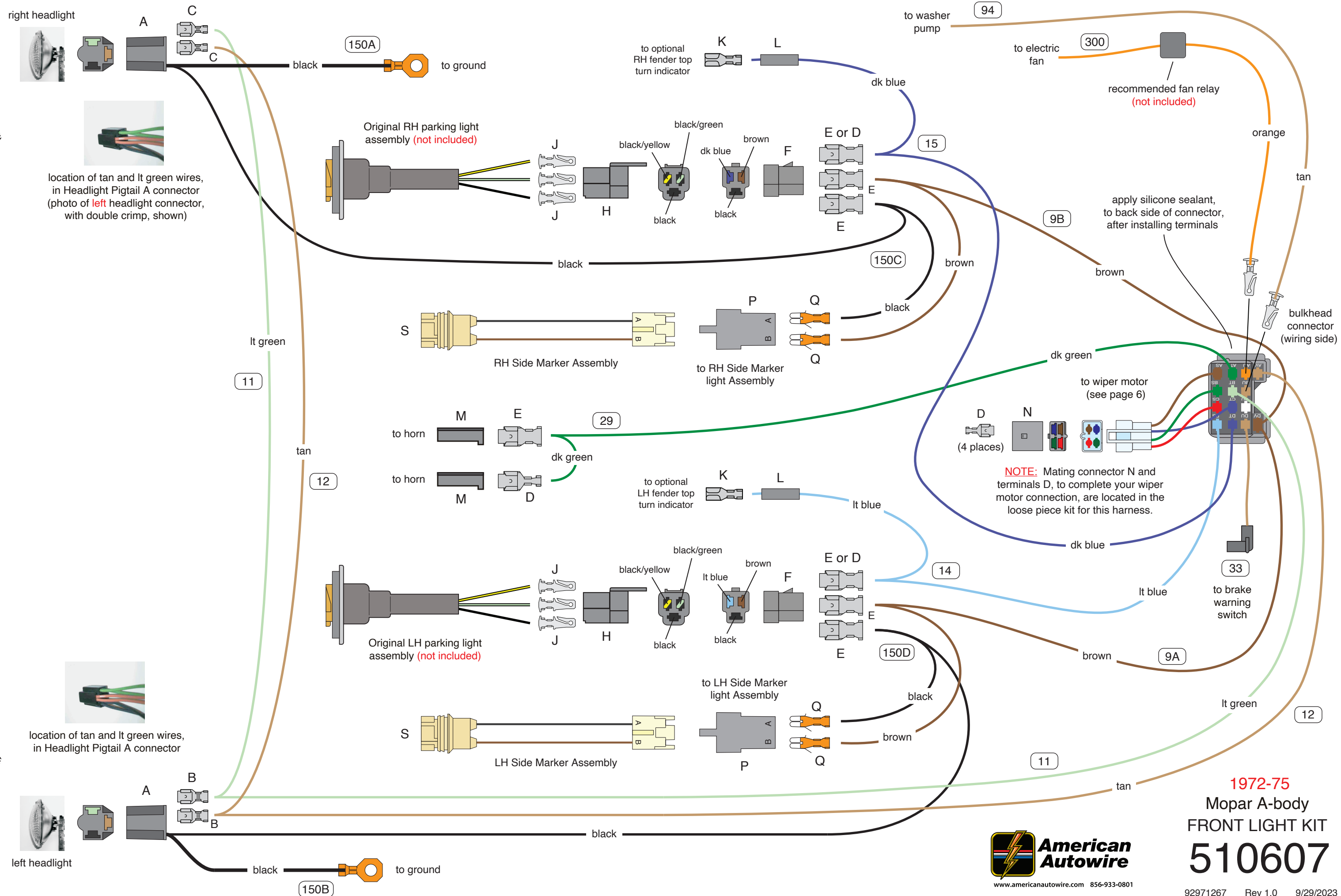

# Wiper motor instructions:

## 2-speed wiper motor wiring:

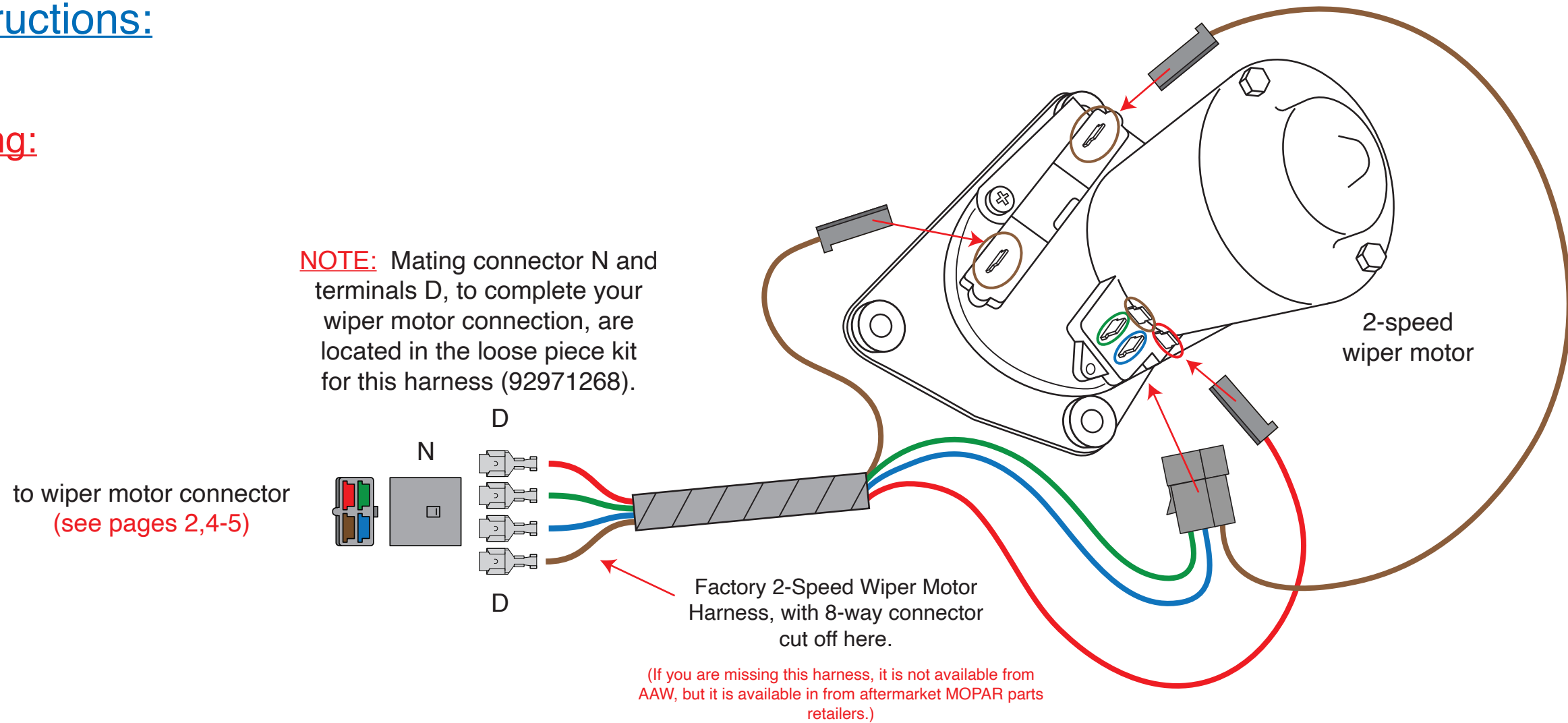

## Variable-speed and 3-speed wiper motor wiring:



www.americanautowire.com 856-933-0801

1972-75 MOPAR A-Body  
Classic Update Series

510607 92971267 Rev 1.0 9/29/2023

